

TRANSMIX 10



The Jacon Transmix 10 has been designed and built for large scale operations requiring high efficiencies.

The Jacon Transmixer range has cabins at both ends of the rig, enabling the operator to drive into a decline and drive out again without turning the machine around. The Jacon Transmix 10 features multi-mode 6 wheel steer functionality and variable hydrostatic transmission which allows maximum speed whilst handling inclines with ease, even when fully laden. Compact and manoeuvrable, the Jacon Transmixers are able to carry all the materials needed to support shotcrete operations performed by its stablemates.

To date, the Transmix 10 is the largest underground concrete mixer in the market providing the client with greater efficiencies to ensure the job is done within the shortest timeframes.

A COMPLETE AND UNIQUE SOLUTION TO BATCH MIXING AND TRANSPORTATION OF CONCRETE IN MINES AND TUNNELS



DIMENSIONS

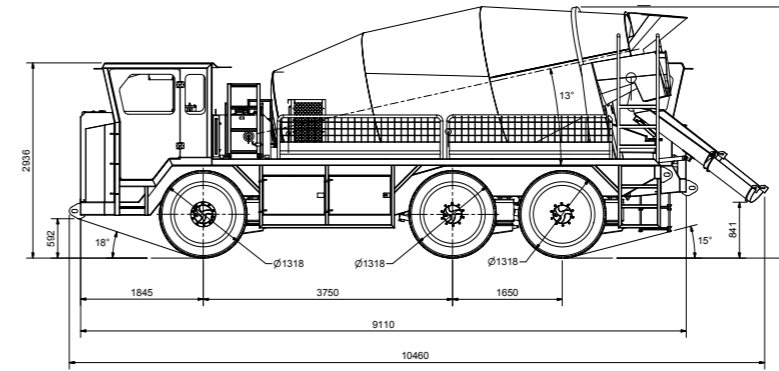

SIDE VIEW

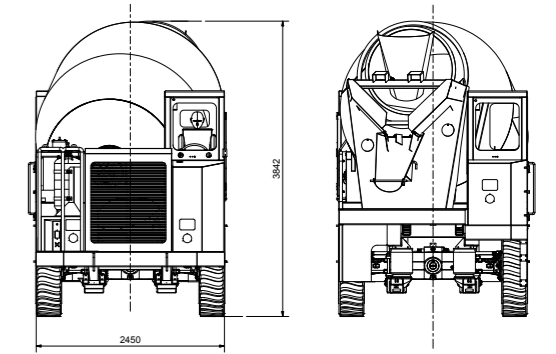

FRONT & BACK VIEW

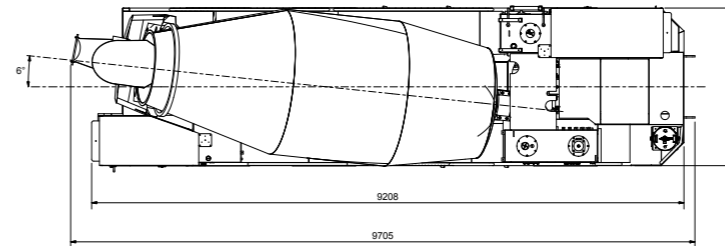

TOP VIEW

SPECIFICATIONS

ENGINE	CAT C13 Tier 3 388KW @ 2100rpm
DRUM CAPACITY	10m ³ bowl
DRIVE	
Diesel-Hydraulic Drive	Standard
Electric-Hydraulic Drive	x
Diesel & Electric Drive	x
DIMENSIONS	
Length	9208
Width	2450
Height	3778
Total Weight (Empty)	18,370kgs
Total Weight (Full Loaded)	43,870kgs
Steering Type	6WD/6WS
TURNING RADIUS	
Inner	R4749
Outer	R8503
DRIVE & GRADEABILITY	
Max Speed @ 0% Grade	Empty: 20 km/h Full: 20km/h
Max Speed @ 5% Grade	Empty: 18.2km/h Full: 16.7km/h
Max Speed @ 10% Grade	Empty: 16.4km/h Full: 13.4km/h
Max Speed @ 15% Grade	Empty: 14.6km/h Full: 10.2km/h
Max Speed @ 20% Grade	Empty: 12.8km/h Full: 6.9km/h
Max Speed @ 25% Grade	Empty: 11km/h Full: 3.6km/h
Max Grade Climb Ability	Full Load: 23% @ 4.9km/h

TURNING RADIUS

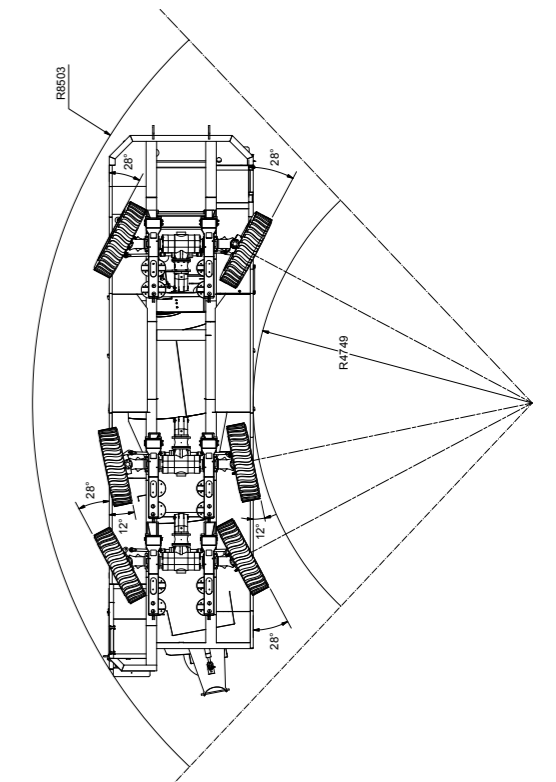

Specifications subject to change without notice | For further equipment details contact info@jacon.com.au